

# ***THERM-O-Mix STATION***

---



***TEMPERED WATER SUPPLY FOR SAFETY SHOWERS***



**WWW.THERMOMEGATECH.COM**

THE MOST ADVANCED, RELIABLE AND COMPACT  
SELF CONTAINED VALVES AVAILABLE FOR TEMPERATURE CONTROL,  
FREEZE PROTECTION, STEAM TRACING AND CONSERVATION OF ENERGY



# Keep Your Safety Shower Safe.

---

When a worker comes into contact with a hazardous material, your eyewash/safety shower station can be your best line of defense. It can do a lot to prevent possible injury, get him back to work fast, and provide him with a feeling of security about his work environment.

That's why your shower's water temperature is so important. Water that's too hot can cause third degree burns in as little as one second. Water that's too cold can discourage workers from washing down for the required 15 minutes, and even cause a dangerous condition like hypothermia.

What you need is an easy-to-use, reliable system that provides water at a temperature that's both safe and comfortable, whenever it's needed. You need the Therm-O-Mix Station or the Therm-O-Mix Station/WWM tempered water supply system.

## The Right Water Temperature Every Time

---

The Therm-O-Mix Station and Therm-O-Mix Station/WWM tempered water supply work simply, economically and reliably. The Therm-O-Mix Station uses a facility's own supply of steam to indirectly heat incoming cold water via a plate-type heat exchanger. The heated water (or the facility's hot water supply, in the case of the Therm-O-Mix/WWM) is then mixed with the requisite amount of cold water until it reaches a temperature of 85°F (29°C) - not warm enough to open skin pores and not cold enough to deter usage.

No other source of energy is required to either heat the water or operate the unit. Steam is only used when the shower/eyewash is activated making it an on demand system. They can be easily installed on existing showers where steam is available.

## Reliability

---

The best way to ensure reliable performance is to start with a system that's built to the highest quality standards. That's what you get with the Therm-O-Mix units. They're designed, built and balanced from the ground up by a single source: Therm-Omega-Tech. We make all the valves and actuators that are used throughout both units and handle total system design and plumbing. Total quality control is in our hands from start to finish, Therm-Omega-Tech is ISO 9001 certified. The result is maximum system integration for greatest efficiency and optimum performance.

## Meeting the Regulations and More

---

The Occupational Safety & Health Administration (OSHA) issues many Regulations (standards) for providing a safe work environment in the industrial setting. One of those regulations is 29 CFR 1910.151(c) which states:

*Where eyes or body of any person may be exposed to injurious corrosive materials, suitable facilities for quick drenching or flushing of the eyes and body shall be provided within the work area for immediate emergency use.*

Though the above regulation is somewhat ambiguous, in numerous interpretations by OSHA of this regulation, they have referred to ANSI standard Z358.1 (ANSI standard for Eyewash and Shower Equipment).

ANSI Standard Z358.1 requires that TEPID FLUSHING FLUID be delivered to the safety shower. They define tepid as moderately warm; lukewarm. In appendix B6 of the 2004 update of this standard ANSI states:

*Recent information indicates that a temperature of 60°F is suitable for the lower parameter for tepid flushing fluid without causing hypothermia to the equipment user.*

ANSI Standard also recommends that showers should *be in accessible locations that require no more than 10 seconds to reach.*

# Is Your Safety Shower Ready For The Cold?

Keeping your safety shower working at optimum performance is important, no matter what the time of year. However, cold winter temperatures can make this especially difficult. Water can freeze in supply lines, clogging the system and shutting off flow. And because water expands as it freezes. Internal pressure in the line can increase enough to break steel pipes and their associated valves and fittings. The result can be costly replacement parts, increased labor costs, and a shower that's out of commission while it's being repaired.

There are a number of steps you can take to prevent cold weather from interfering with safety shower performance. Many are relatively simple to implement and can be readily put in place before cold weather begins.

## Techniques For Freeze Protection

Two basic techniques are used to keep water pipes from freezing: tracing (electrical or steam) and bleed/drain. In electrical tracing, an electrical heating cable is fastened to the underside of the pipe, beneath the insulation. The heat generated by the cable offsets the heat loss of the pipe so the pipe and water it contains are kept above freezing. Tracing is particularly effective if the discharge from bleeder or drain valves present a handling problem. This may be the case in plant areas where all discharge must be controlled or reported, or where discharge treatment problems and expenses outweigh the benefits of bleeder/drain valves.

But electrical tracing is not without problems. In large installations, it may be prohibitively expensive to install and maintain. It may also be ineffective, if a cable breaks, for example, parts of the system may be vulnerable to freezing. And if the power goes out, the entire system could be rendered inoperable. It also may be dangerous in a facility handling combustible substances, because of the possibility of sparking.

In steam tracing, the electric cable is replaced by a small-diameter tubing connected to a steam supply. This system depends on steam traps located at the end of the tracing line to maintain heat. If these traps fail, the pipeline could be left unprotected. Also, an electrical power failure typically results in boiler shutdown and consequent loss of protection.

<b>US National Standard Emergency Eyewash and Shower Equipment</b>	
<b>Shower</b>	
Shower Height	82" to 96" from standing height.
Water spray pattern	20" minimum diameter - 60" from standing level.
Center of water spray	16" from any obstruction.
Potable water delivery	Minimum of 20gpm/meeting water spray pattern.
Control valve and actuator	"Stay on" type - Off to On in one second - easily located.
Location to hazard	Maximum 10 seconds travel and within 100 feet of hazard.
Identification	Well lit, sign, area highly visible.
<b>Eye/Face Wash</b>	
Potable water delivery	Minimum of 0.4 gpm - dual stream flushing.
Velocity	Soft spent stream.
Location to hazard	Maximum 10 seconds travel and within 100 feet of hazard.
Nozzles	Covers to protect from airborne contaminants.
Nozzle height	Not less than 33" nor more than 45" from standing level.
Control valve and actuator	"Stay on" type - Off to On in one second - easily located.
Identification	Well lit, sign, area highly visible.
<b>Other Considerations</b>	
Delivered water temp.	Tepid
Freeze protection required	Manual or electrical.
Hostile environment protection	Enclosure - heated/non-heated.
Alarms required	Local and/or remote.
Modesty consideration	Does not discourage equipment use.
Medical assistance	Available in plant or outside.
Emergency vehicle	Available in plant or outside.
Inspection	Monthly record should be maintained.
Maintenance	Each unit activated weekly to flush line and verify flow.
Training	Instruct all employees on proper use of equipment.

The second method, the bleed/drain technique, relies on self-actuated valves installed at various points throughout the system. These valves operate by draining or bleeding water as the temperature approaches freezing. Each valve contains a temperature-sensitive material that contracts when exposed to water temperature between 40°F and 35°F, allowing the valve to open and water to flow. As the water temperature in the valve approaches 40°F, the thermal material expands and closes the valve. In this way, cold water is eventually bled from the system and replaced by warmer water from the underground supply line, keeping the water in the system at about 40°F or higher.

Self-actuated valves have significant advantages over tracing systems. They are generally more economical to install and operate, particularly in remote areas where steam or electricity is not available and the cost to provide them is high. And because valves have no power requirements, they can continue to operate when there's a power failure. For this reason, freeze protection valves often are used as backup protection even on steam or electrically traced systems.

## The Importance of Scald Protection

Scald protection may seem unnecessary during the cold winter months, but this is not the case. Solar radiation can elevate the water temperature in outdoor units to where it is high enough to cause third degree burns. If steam or electric tracing is installed, excessive heat output can also heat water in the pipe to dangerously high temperature conditions from process, steam or condensate lines.

Here, again the installation of self-actuated valves can prevent problems from occurring. Scald protection valves operate like valves used for freeze prevention. Instead of draining the system of cold water when the temperature nears freezing, however, these valves open gradually as water temperature rises above 95°F, reaching full flow at 105°F or above. As a result, hot water is purged from the system and replaced by cooler water in the supply line.

Scald protection valves should be installed so the full shower station and system piping can be purged of hot water.

### Variables Attributable to Third Degree Burn\*

Water Temp. (F°)	Exposure time
120	9.5 minutes
125	2.0 minutes
130	30 seconds
140	15 seconds
150	1.8 seconds
158	1.0 seconds

\*From studies conducted by Lewis & Love (1926; Wu. Yung-Chi, N.B.S. (1972); Dr. M.A. Stoll, for U.S. Navy (1979)

## It's Not Too Early

The time to winterize your safety shower is before cold weather sets in. The earlier it is done, the better your facility will be able to avoid problems once temperature drops.

Take time to evaluate your system now to determine whether it is adequately prepared to handle cold temperatures. Survey your system and list any modifications that can make them better, then take the necessary steps to put them in place.

# THERM-O-MIX STATION

## Features

- ◆ Uses existing plant steam and water supply
- ◆ Provides 3 to 30 GPM of 85°F with an inlet water pressure of 45 PSIG
- ◆ Easy to install on any existing shower or eyewash/shower combination
- ◆ Compact, lightweight design easily supported by pipe connections or factory mounting kit
- ◆ Plant steam and water never mix... uses compact heat exchanger
- ◆ Maintains constant 85°F output regardless of inlet water temperature (between 40°F and 85°F)
- ◆ Preheated to provide instantaneous 85°F water
- ◆ Freeze and solar over-temperature protection and bleeder valves included
- ◆ No insulated tanks or expensive recirculation systems required
- ◆ Operates on typical plant steam pressure (45 PSIG recommended)
- ◆ Self-purging... no need for elaborate drainage system
- ◆ All components are in-line field serviceable
- ◆ Durable NEMA-4 enclosure can be readily removed for servicing
- ◆ Union connections allow for quick and easy installation
- ◆ Conforms to OSHA and ANSI recommendations
- ◆ Steam trap on steam inlet included

## Options

- ◆ Double walled heat exchanger
- ◆ Cover for double walled heat exchanger
- ◆ Alarms that indicate when the system is in use
- ◆ NEMA-4 enclosure for the Therm-O-Mix/WWM unit
- ◆ Enclosure air purge fittings and stainless steel inlet fittings for corrosive environments.

## Redundant Control

Level 1: (V-1) This valve mixes heated and cold water and compensates for the pressure drop through the heat exchanger and associated piping.

Level 2: (V-2) This valve senses the temperature of the hot water outlet from the heat exchanger and modulates inlet steam flow to maintain hot water outlet design temperature

Level 3: (V-3) When water flow is activated at shower or eyewash, the pressure sensing diaphragm of V-3 opens the steam valve to begin water heating.

Level 4: (V-4) Heat sensor valve V-4 opens and equalizes pressure on the high and low pressure side of the V-3 diaphragm control valve preventing steam flow if outlet water is above design temperature.



**NOTE:** Therm-O-Mix Station does not include shower or eyewash components.

# THERM-O-MIX STATION/WWM

## THE NEED

An instantaneous and reliable source of tempered water for a safety shower/eyewash system using existing hot and cold water supply.

## THE PROBLEM

Conventional mixing valves are unsuitable as the means to provide tempered water at safety shower/eyewash stations. These valves by nature have the property of shutting off entirely if either the hot or cold water supply is interrupted. This is dangerous and unacceptable for safety shower/eyewash systems where cold water must be available under all circumstances. To meet today's OSHA and ANSI recommendations you must have a system which can respond safely to both hot water and cold water supply failures.

## THE SOLUTION

The **Therm-O-Mix Station/WWM**. It's WM-1 mixing valve acting in concert with it's unique PWM-1 pressure sensing controller assure that cold water will flow to the shower and eyewash even if no hot water is available (as long as the cold water supply is not shut off elsewhere in the system). This is accomplished using completely mechanical, self operating controls. No electricity or air required.



## TRIPLE REDUNDANT SAFETY CONTROLS

### **PWM-1 Pressure Sensing Controller:**

Therm-Omega-Tech's unique diaphragm operated valve actuator senses the water pressures on both the hot and cold water inlet connections. If hot water pressure is not present at the mixing valve inlet, this actuator will override the mixing valve and allow full flow of cold water. If no cold water pressure is available at the mixing valve inlet, both the mixing valve and the diaphragm actuator will close off the hot port to prevent dangerously hot water from flowing to the shower/eyewash system.

### **WM-1 Mixing Valve:**

The primary temperature control device is Therm-Omega-Tech's three-way mixing valve. This valve is designed around our exclusive Thermoloid® sensor/actuator that automatically and accurately proportions the water flow in response to outlet water temperature. This mixing valve simultaneously modulates both the hot and cold water inlet ports to provide 85°F water to the shower/eyewash system. The Thermoloid® sensor/actuator is the most advanced and reliable thermal actuator of its type available today.

### **V-4 Final Safety Control:**

This control element senses the final water temperature and will position the PWM-1 pressure sensing controller to close off the hot water port of the mixing valve if the final water temperature is above 90°F.

## FEATURES

- ◆ Uses existing plant hot and cold water supplies
- ◆ All components are in-line serviceable
- ◆ Provides 3 to 30 GPM of 85°F water with inlet pressure of 30 PSIG
- ◆ Optional durable, all weather version in high visibility NEMA-4 enclosure available
- ◆ Compact, lightweight design easily supported by piping connections (under 15 lbs/6 kg)
- ◆ Easy to retrofit on existing shower or combination shower/eyewash systems
- ◆ Maintains constant 85°F (29°C) output regardless of inlet pressure and temperature variations
- ◆ All self-operating controllers - no power required

# THERM-O-MIX STATION MOUNTING KIT

## DESIGN FEATURES

- ◆ All components are galvanized steel.
- ◆ Kit weight: 18 lbs. (8.1 Kg.)
- ◆ Proper testing and service of **Therm-O-Mix® Station** requires access to inside of enclosure. Minimum offset from enclosure to wall should be 7 inches (17.78 cm).
- ◆ This mounting kit is specifically designed to provide secure, rigid mounting without limiting access. This mounting kit is specifically designed to be rigid and mounted in a correct manner.

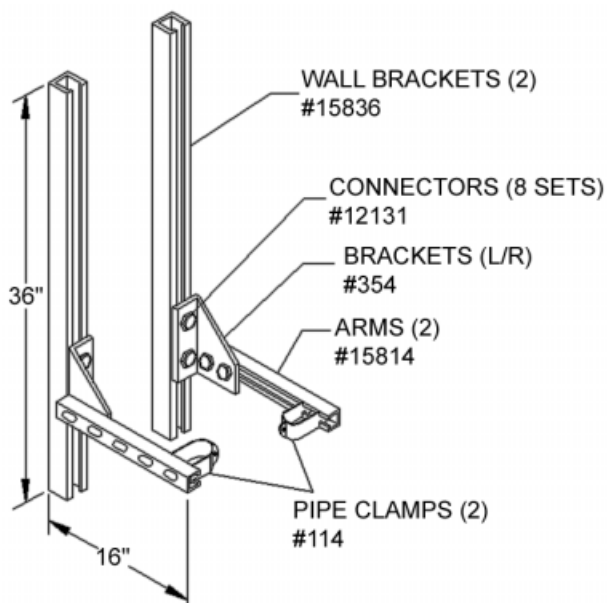
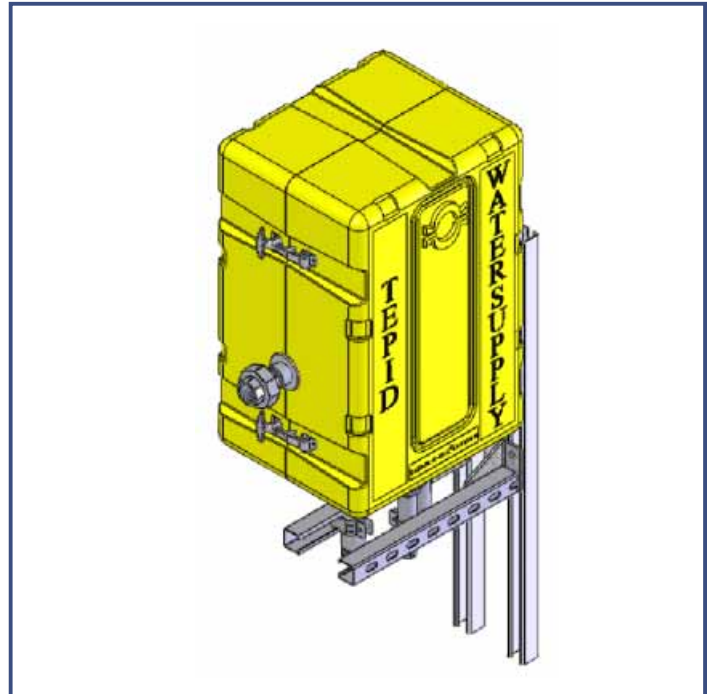

**THERM-O-MIX® STATION MOUNTING KIT**

### NOTES:

1. Proper testing and service of the Therm-O-Mix Station requires access to the inside of enclosure. Minimum offset from enclosure to wall should be 7.0" (17.8 cm).
2. Typical Therm-O-Mix Station weight:  
BPHE = 90 lbs. (41 Kg).
3. Moly or lag bolts to secure wall brackets to wall are NOT included. ½" (13mm) size diameter are recommended.

For a copy of specific product data sheets please visit our website at [www.thermomegatech.com](http://www.thermomegatech.com)

Contact your local representative for information on our full product line.



**[WWW.THERMOMEGATECH.COM](http://WWW.THERMOMEGATECH.COM)**

**353 IVYLAND RD. WARMINSTER, PA 18974-2205**

**Phone: (877) FRZ-VALVE (379-8258) or (215) 674-9992**

**Fax: (267) 280-1100**

**Email: [valves@thermomegatech.com](mailto:valves@thermomegatech.com)**