



MODEL DTV-R DRAIN TEMPERING VALVE

**FREEZE PROBLEMS?
CALL THE GURU 1-877-FRZ-VALVE**

DESIGN FEATURES

- ◆ Rugged, clog resistant valve design
- ◆ Easily installed using standard pipe fittings and tools
- ◆ Operates in any orientation
- ◆ Modulates over operating temperature range to conserve cooling water
- ◆ Effluent tempering capacity limited only by cold water flow rate through DTV-R

TYPICAL USES

- ◆ Boiler blowdown drain lines
- ◆ Condensate return headers
- ◆ Heat exchanger backup cooling
- ◆ Dehumidifier discharge to sewer/drain
- ◆ Any excessively hot effluent flow to sewer/drain
- ◆ Condensate discharge from steam traps directly to sewer



APPLICATIONS

The **DTV-R** valve can be used in applications where a discharge flow to a drain or sewer must be tempered with cold water to reduce temperature. In some areas, plumbing codes dictate a maximum allowable sewer discharge temperature. The **DTV-R** provides a convenient, economical, and easy to use method of tempering hot effluent flows. Since the **DTV-R** is open only when the effluent exceeds the specified setpoint temperature, it also conserves water by automatically turning off cold water when not needed.

OPERATION

The hot effluent to be tempered is connected to the drain/sewer line using a suitably sized tee fitting and piping sized to handle the effluent flow rates. See sample calculation below and typical installation drawing on next page. The hot effluent passes over the thermal actuator of the **DTV-R** valve and this actuator controls the cold water inlet port. If the hot effluent is above the specified setpoint, the **DTV-R** opens the cold water inlet port to allow injection of cold water. As the hot effluent cools, the **DTV-R** valve automatically modulates to reduce the cold water inlet flow. At about 10°F below the full open temperature, the cold water inlet is fully closed to conserve water.

SAMPLE CALCULATION

How much effluent can be tempered with a DTV-R valve?

1) Flow capacity through cold water port of DTV-R with Cv = 2.0:

$$CW \text{ gpm} = C_v \times \sqrt{\text{pressure drop}}$$

Assume 50 psig cold water pressure, drain pressure = 0psig

$$CW \text{ gpm} = 2 \times \sqrt{50} = 14.1 \text{ gpm}$$

Assume for this example:

cold water temp = 60°F (CT)

hot effluent temp = 212°F (HT)

max. allowable drain temp = 140°F

2) Maximum effluent flow (gpm) that can be tempered:

$$CW \times (MT-CT)/(HT-MT)$$

$$MT-CT=80$$

$$HT-MT=72$$

$$\text{Maximum effluent flow rate} = 14.1 \times 80/72 = 15.6 \text{ gpm}$$

MODEL DTV-R

DRAIN TEMPERING VALVE

PARTS AND MATERIALS

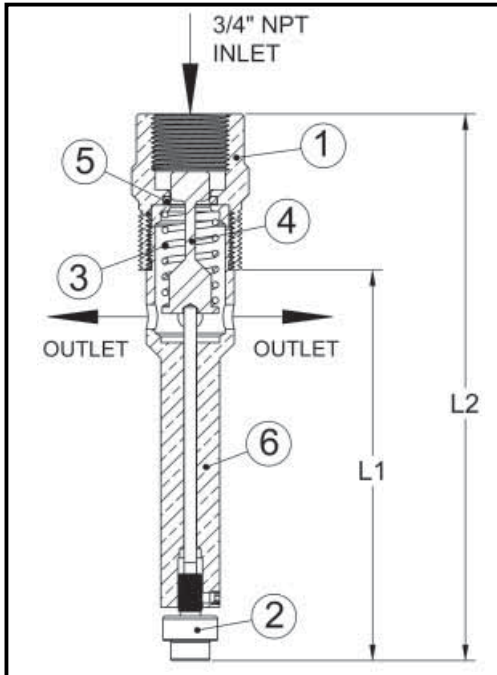

ITEM	DESCRIPTIONS	MATERIAL
1	VALVE BODY	BRASS or 300 SERIES S.S.
2	THERMAL ACTUATOR	BRASS or 300 SERIES S.S.
3	OPERATING SPRING	300 SERIES STAINLESS
4	RAM-TYPE PLUG	BRASS or 300 SERIES S.S.
5	SEAT SEAL	PTFE
6	PISTON	300 SERIES STAINLESS

TYPICAL INSTALLATION

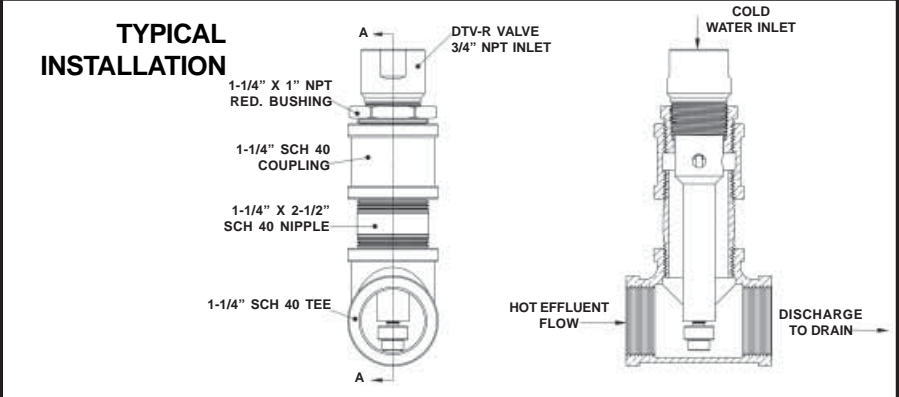

SPECIFICATIONS

Size (NPT)		L1		L2		Weight		Cv	Maximum Inlet Water Pressure	Maximum Temperature
Water Inlet	Drain Connection	in	mm	in	mm	Lb	Kg			
3/4"	1"	5.75	146	7.0	178	1.5	0.68	2.0	100 PSIG (6.8 BAR)	250°F (121°C)

TO ORDER, SPECIFY:

Part Number	Description
326-000000-XXX	DTV-R Valve
326-100000-XXX	DTV-R Valve S.S.

Notes:

- Standard temperatures "XXX" available: 040, 045, 050, 060, 070, 075, 085, 095, 100, 105, 110, 115, 120, 125, 130, 140, 150, 160, 170, 175, 180, 190, 200 and 210°F.
- A #20 mesh strainer is recommended for use with all port sizes

Therm-Omega-Tech, Inc. reserves the right to change the design and specifications without notice



THEM-OMEGA-TECH, INC.

353 Ivyland Road, Warminster, PA 18974-2205
Phone: 215-674-9992 Fax: 215-674-8594

CALL THE VALVE GURU TOLL FREE

1-877-FRZ-VALVE (379-8258)

Visit our internet site at: <http://www.thermomegatech.com> email: valves@thermomegatech.com